

Standard materials: Polyamide.
See page 9.
Standard colour: Natural - coloured.

The advantages of using uni-chains two part sprockets are that they make mounting and replacing easier.

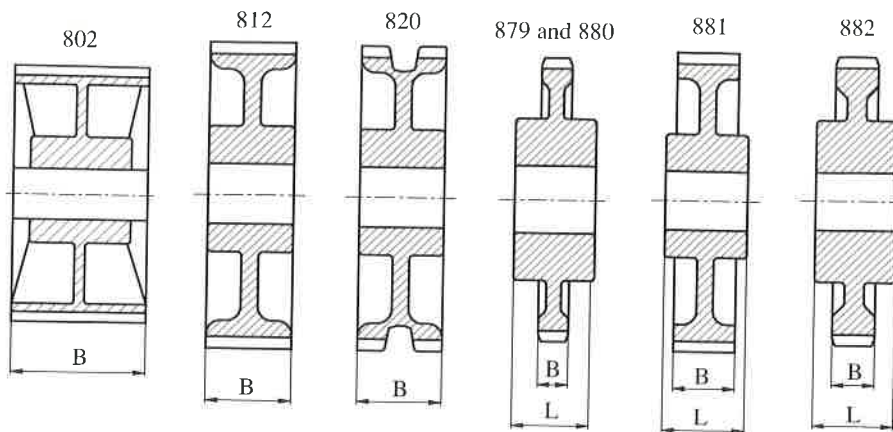

uni reference-no.	no. of teeth	bore				pitch diameter		overall diameter		hub diameter		tooth width B	
		min mm	inch	max mm	inch	mm	inch	mm	inch	mm	inch	mm	inch
Two part sprockets for 800, 802, 805 and 821													
3-802-25 N TP	25	30	1.18	50.8	2	153.2	6.03	154.2	6.07	58	2.28	80.2	3.16
Two part sprockets for 810, 812 and 815													
3-815-19 N TP	19	20	0.78	40	1.57	117.3	4.62	117.1	4.61	58	2.28	42.3	1.67
3-815-21 N TP	21	20	0.78	40	1.57	129.3	5.09	130.0	5.12	58	2.28	42.3	1.67
3-815-23 N TP	23	20	0.78	40	1.57	141.2	5.56	142.0	5.59	58	2.28	42.3	1.67
3-815-25 N TP	25	20	0.78	40	1.57	153.2	6.03	154.2	6.07	58	2.28	42.3	1.67
Two part sprockets for 820 and 831													
3-820-19 N TP	19	20	0.78	40	1.57	117.3	4.62	117.1	4.61	58	2.28	42.3	1.67
3-820-21 N TP	21	20	0.78	40	1.57	129.3	5.09	130.0	5.12	58	2.28	42.3	1.67
3-820-23 N TP	23	20	0.78	40	1.57	141.2	5.56	142.0	5.59	58	2.28	42.3	1.67
3-820-25 N TP	25	20	0.78	40	1.57	153.2	6.03	154.2	6.07	58	2.28	42.3	1.67

uni reference-no.	no. of teeth	bore				pitch diameter		overall diameter		hub diameter		hub width B		tooth width B	
		min mm	inch	max mm	inch	mm	inch	mm	inch	mm	inch	mm	inch	mm	inch
Two part Sprockets for 879 and 880															
3-880-9 N TP	9	20	0.78	40	1.57	111.4	4.39	110.0	4.33	52	2.05	42.3	1.67	15.8	0.62
3-880-10 N TP	10	20	0.78	40	1.57	123.3	4.85	122.4	4.82	52	2.05	42.3	1.67	15.8	0.62
3-880-11 N TP	11	20	0.78	40	1.57	135.2	5.32	134.9	5.31	52	2.05	42.3	1.67	15.8	0.62
3-880-12 N TP	12	20	0.78	40	1.57	147.2	5.80	147.3	5.80	52	2.05	42.3	1.67	15.8	0.62
Two part sprockets for 881															
3-881-19 N TP	19	20	0.78	40	1.57	117.3	4.62	117.1	4.61	58	2.28	42.3	1.67	31.8	1.25
3-881-21 N TP	21	20	0.78	40	1.57	129.3	5.09	130.0	5.12	58	2.28	42.3	1.67	31.8	1.25
3-881-23 N TP	23	20	0.78	40	1.57	141.2	5.56	142.0	5.59	58	2.28	42.3	1.67	31.8	1.25
3-881 25 N TP	25	20	0.78	40	1.57	153.2	6.03	154.2	6.07	58	2.28	42.3	1.67	31.8	1.25
Two part sprockets for 882															
3-882 10 N TP	10	20	0.78	40	1.57	123.3	4.85	125.0	4.92	52	2.05	42.3	1.67	22.2	0.87
3-882 11 N TP	11	20	0.78	40	1.57	135.2	5.32	137.4	5.41	58	2.28	42.3	1.67	22.2	0.87
3-882 12 N TP	12	20	0.78	40	1.57	147.2	5.80	149.9	5.90	58	2.28	42.3	1.67	22.2	0.87